

# Interstitial Cystitis/ Painful Bladder Syndrome

*National Kidney and Urologic Diseases Information Clearinghouse*



U.S. Department  
of Health and  
Human Services

NATIONAL  
INSTITUTES  
OF HEALTH

**NIDDK**  
NATIONAL INSTITUTE OF  
DIABETES AND DIGESTIVE  
AND KIDNEY DISEASES

## What is IC/PBS?

Interstitial cystitis (IC) is a condition that results in recurring discomfort or pain in the bladder and the surrounding pelvic region. The symptoms vary from case to case and even in the same individual. People may experience mild discomfort, pressure, tenderness, or intense pain in the bladder and pelvic area. Symptoms may include an urgent need to urinate, a frequent need to urinate, or a combination of these symptoms. Pain may change in intensity as the bladder fills with urine or as it empties. Women's symptoms often get worse during menstruation. They may sometimes experience pain during vaginal intercourse.

Because IC varies so much in symptoms and severity, most researchers believe it is not one, but several diseases. In recent years, scientists have started to use the terms bladder pain syndrome (BPS) or painful bladder syndrome (PBS) to describe cases with painful urinary symptoms that may not meet the strictest definition of IC. The term IC/PBS includes all cases of urinary pain that can't be attributed to other causes, such as infection or urinary stones. The term interstitial cystitis, or IC, is used alone when describing cases that meet all of the IC criteria established by the National Institute of Diabetes and Digestive and Kidney Diseases (NIDDK).

In IC/PBS, the bladder wall may be irritated and become scarred or stiff. Glomerulations—pinpoint bleeding—often appear on the bladder wall. Hunner's ulcers—patches of broken skin found on the bladder wall—are present in 10 percent of people with IC.

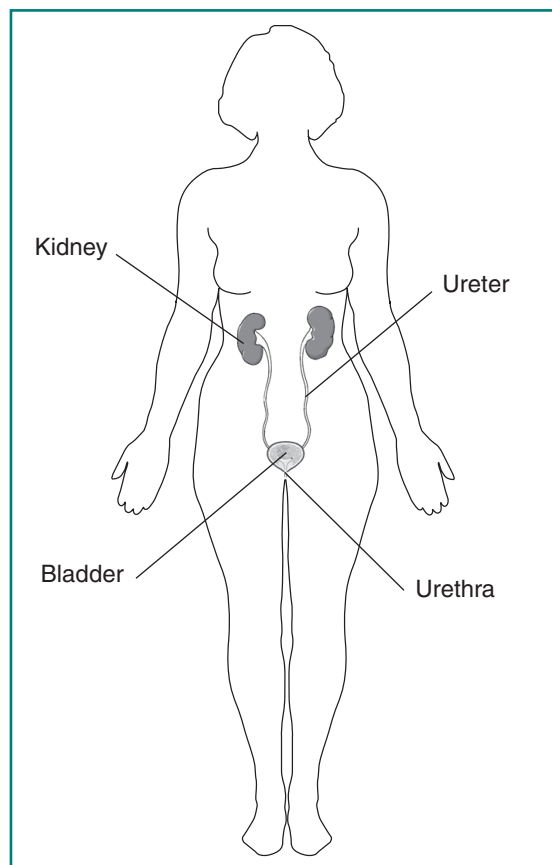

The urinary system

Some people with IC/PBS find that their bladder cannot hold much urine, which increases the frequency of urination. Frequency, however, is not always specifically related to bladder size; many people with severe frequency have normal bladder capacity when measured under anesthesia or during urologic testing. People with severe cases of IC/PBS may urinate as many as 60 times a day, including frequent nighttime urination, also called nocturia.

IC/PBS is far more common in women than in men. Of the estimated 1.3 million Americans with IC/PBS, more than 1 million are women.<sup>1</sup>

## What causes IC/PBS?

Some of the symptoms of IC/PBS resemble those of bacterial infection, but medical tests reveal no organisms in the urine of people with IC/PBS. Furthermore, people with IC/PBS do not respond to antibiotic therapy. Researchers are working to understand the causes of IC/PBS and to find effective treatments.

Many women with IC/PBS have other conditions such as irritable bowel syndrome and fibromyalgia. Scientists believe IC/PBS may be a bladder manifestation of a more general condition that causes inflammation in various organs and parts of the body.

Researchers are beginning to explore the possibility that heredity may play a part in some forms of IC. In a few cases, IC has affected a mother and a daughter or two sisters, but it does not commonly run in families.

## How is IC/PBS diagnosed?

Because symptoms are similar to those of other disorders of the bladder and there is no definitive test to identify IC/PBS, doctors must rule out other treatable conditions before considering a diagnosis of IC/PBS. The most common of these diseases in both sexes are urinary tract infections and bladder cancer. In men, common diseases include chronic prostatitis or chronic pelvic pain syndrome. In women, endometriosis is a common cause of pelvic pain. IC/PBS is not associated with any increased risk of developing cancer.

The diagnosis of IC/PBS in the general population is based on the

- presence of pain related to the bladder, usually accompanied by frequency and urgency of urination
- absence of other diseases that could cause the symptoms

Diagnostic tests that help rule out other diseases include urinalysis, urine culture, cystoscopy, biopsy of the bladder wall and urethra, and distention of the bladder under anesthesia.

---

<sup>1</sup>Clemens JQ, Joyce GF, Wise M, Payne CK. Interstitial cystitis and painful bladder syndrome. In: Litwin MS, Saigal CS, eds. *Urologic Diseases in America*. U.S. Department of Health and Human Services, Public Health Service, National Institutes of Health, National Institute of Diabetes and Digestive and Kidney Diseases. Washington, D.C.: U.S. Government Printing Office; 2007. NIH publication 07-5512:123-154.

## Urinalysis and Urine Culture

Examining urine with a microscope and culturing the urine can detect and identify the primary organisms that are known to infect the urinary tract and that may cause symptoms similar to IC/PBS. A urine sample is obtained either by catheterization or by the clean catch method. For a clean catch, the patient washes the genital area before collecting urine midstream in a sterile container. White and red blood cells and bacteria in the urine may indicate an infection of the urinary tract, which can be treated with an antibiotic. If urine is sterile for weeks or months while symptoms persist, the doctor may consider a diagnosis of IC/PBS.

## Culture of Prostate Secretions

Although not commonly done, in men without a history of culture-documented urinary tract infections, the doctor might obtain prostatic fluid and examine it for signs of a prostate infection, which can then be treated with antibiotics.

## Cystoscopy under Anesthesia with Bladder Distention

The doctor may perform a cystoscopic examination in order to rule out bladder cancer. During cystoscopy, the doctor uses a cystoscope—an instrument made of a hollow tube about the diameter of a drinking straw with several lenses and a light—to see inside the bladder and urethra. The doctor might also distend or stretch the bladder to its capacity by filling it with a liquid or gas. Because bladder distention is painful for people with IC/PBS, they must be given some form of anesthesia for the procedure.

## Biopsy

A biopsy is a tissue sample that can be examined with a microscope. Tissue samples of the bladder and urethra may be removed during a cystoscopy. A biopsy helps rule out bladder cancer.

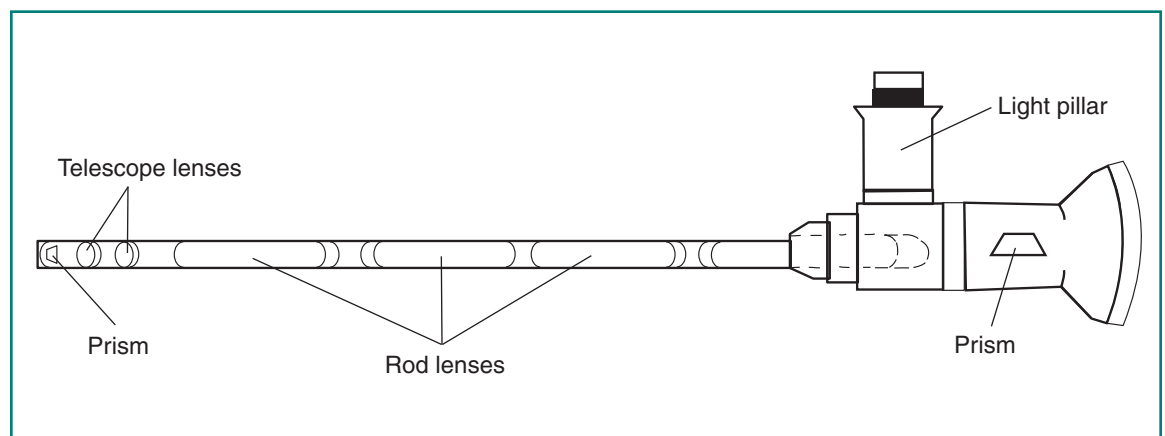

Cystoscope

## What are the treatments for IC/PBS?

Scientists have not yet found a cure for IC/PBS, nor can they predict who will respond best to which treatment. Symptoms may disappear with a change in diet or treatments or without explanation. Even when symptoms disappear, they may return after days, weeks, months, or years. Scientists do not know why.

Because the causes of IC/PBS are unknown, current treatments are aimed at relieving symptoms. Many people are helped for variable periods by one or a combination of treatments. As researchers learn more about IC/PBS, the list of potential treatments will change, so patients should discuss their options with a doctor.

### Bladder Distention

Many people with IC/PBS have noted an improvement in symptoms after a bladder distention has been done to diagnose the condition. In many cases, the procedure is used as both a diagnostic test and initial therapy. Researchers are not sure why distention helps, but some believe it may increase capacity and interfere with pain signals transmitted by nerves in the bladder. Symptoms may temporarily worsen 4 to 48 hours after distention, but should return to predistention levels or improve within 2 to 4 weeks.

### Bladder Instillation

During a bladder instillation, also called a bladder wash or bath, the bladder is filled with a solution that is held for varying periods of time, averaging 10 to 15 minutes, before being emptied.

The only drug approved by the U.S. Food and Drug Administration (FDA) for bladder instillation is dimethyl sulfoxide (Rimso-50), also called DMSO. DMSO treatment involves guiding a narrow tube called a catheter up the urethra into the bladder. A measured amount of DMSO is passed through the catheter into the bladder, where it is retained for about 15 minutes before being expelled. Treatments are given every week or two for 6 to 8 weeks and repeated as needed. Most people who respond to DMSO notice improvement 3 or 4 weeks after the first 6- to 8-week cycle of treatments. Highly motivated patients who are willing to catheterize themselves may, after consultation with their doctor, be able to have DMSO treatments at home. Self-administration is less expensive and more convenient than going to the doctor's office.

Doctors think DMSO works in several ways. Because it passes into the bladder wall, it may reach tissue more effectively to reduce inflammation and block pain. It may also prevent muscle contractions that cause pain, frequency, and urgency.

A bothersome but relatively insignificant side effect of DMSO treatments is a garliclike taste and odor on the breath and skin that may last up to 7 hours after treatment. Long-term treatment has caused cataracts in animal studies, but this side effect has not appeared in humans. Blood tests, including a complete blood count and kidney and liver function tests, should be done about every 6 months.

## Oral Drugs

### **Pentosan Polysulfate Sodium (Elmiron)**

This first oral drug developed for IC was approved by the FDA in 1996. In clinical trials, the drug improved symptoms in 30 percent of patients treated. Doctors do not know exactly how the drug works, but one theory is that it may repair defects that might have developed in the lining of the bladder.

The FDA-recommended oral dosage of Elmiron is 100 milligrams (mg), three times a day. Patients may not feel relief from IC pain for the first 4 months. A decrease in urinary frequency may take up to 6 months. Patients are urged to continue with therapy for at least 6 months to give the drug an adequate chance to relieve symptoms. If 6 months of Elmiron therapy provides no benefit, it is reasonable to stop the drug.

Elmiron's side effects are limited primarily to minor gastrointestinal discomfort. A small minority of patients experienced some hair loss, but hair grew back when they stopped taking the drug. Researchers have found no negative interactions between Elmiron and other medications.

Elmiron may affect liver function, which should therefore be monitored by the doctor.

Because Elmiron has not been tested in pregnant women, the manufacturer recommends it not be used during pregnancy, except in the most severe cases. Because Elmiron has mild blood-thinning effects, it should be discontinued prior to planned surgery.

### **Other Oral Medications**

Aspirin and ibuprofen may be a first line of defense against mild discomfort. Doctors may recommend other drugs to relieve pain.

Some people have experienced improvement in their urinary symptoms by taking tricyclic antidepressants or antihistamines. A tricyclic antidepressant called amitriptyline (Elavil) may help reduce pain, increase bladder capacity, and decrease frequency and nocturia. Some people may not be able to take it because it makes them too tired during the day. In people with severe pain, narcotic analgesics such as acetaminophen (Tylenol) with codeine or longer-acting narcotics may be necessary.

All drugs—even those sold over the counter—have side effects. A person should always consult a doctor before using any drug for an extended amount of time.

## Electrical Nerve Stimulation

Mild electrical pulses can be used to stimulate the nerves to the bladder—either through the skin or with an implanted device. The method of delivering impulses through the skin is called transcutaneous electrical nerve stimulation (TENS). With TENS, mild electric pulses enter the body for minutes to hours, two or more times a day either through wires placed on the lower back or just above the pubic area—between the navel and the pubic hair—or through special devices inserted into the vagina in women or into the rectum in men. Although scientists do not know exactly how TENS relieves pelvic pain, it has been suggested that the electrical pulses may increase blood flow to the bladder, strengthen pelvic muscles that help control the bladder, or trigger the release of substances that block pain.

TENS is relatively inexpensive and allows people with IC/PBS to take an active part in treatment. Within some guidelines, the patient decides when, how long, and at what intensity TENS will be used. It has been most helpful in relieving pain and decreasing frequency in people with Hunner's ulcers. Smokers do not respond as well as nonsmokers. If TENS is going to help, improvement is usually apparent in 3 to 4 months.

A person may consider having a device implanted that delivers regular impulses to the bladder. A wire is placed next to the tailbone and attached to a permanent stimulator under the skin. The FDA has approved this

device, marketed as the Inter-Stim system, to treat urge incontinence, urgency-frequency syndrome, and urinary retention in people for whom other treatments have not worked.

## Diet

No scientific evidence links diet to IC/PBS, but many patients find that alcohol, tomatoes, spices, chocolate, caffeinated and citrus beverages, and high-acid foods may contribute to bladder irritation and inflammation. Some people also note that their symptoms worsen after eating or drinking products containing artificial sweeteners. Eliminating various items from the diet and reintroducing them one at a time may determine which, if any, affect a person's symptoms. However, maintaining a varied, well-balanced diet is important.

## Smoking

Many people feel smoking makes their symptoms worse. How the by-products of tobacco that are excreted in the urine affect IC/PBS is unknown. Smoking, however, is a major cause of bladder cancer. One of the best things smokers can do for their bladder and their overall health is to quit.

## Exercise

Many patients feel that gentle stretching exercises help relieve IC/PBS symptoms.

## Bladder Training

People who have found adequate relief from pain may be able to reduce frequency by using bladder training techniques. Methods vary, but basically patients decide to void—empty their bladder—at designated times and use relaxation techniques and distractions to keep to the schedule. Gradually, they try to lengthen the time between scheduled voids. A diary in which to record voiding times is helpful in keeping track of progress.

## Physical Therapy

New evidence indicates that certain types of physical therapy, when administered by an experienced physical therapist, may improve IC/PBS symptoms. Patients should discuss this option with their health care provider.

## Surgery

Surgery should be considered only if all available treatments have failed and the pain is disabling. Many approaches and techniques are used, each of which has advantages and complications that should be discussed with a surgeon. A doctor may recommend consulting another surgeon for a second opinion before taking this step. Most surgeons are reluctant to operate because some people still have symptoms after surgery.

People considering surgery should discuss the potential risks and benefits, side effects, and long- and short-term complications with a surgeon, their family, and people who have already had the procedure. Surgery requires anesthesia, hospitalization, and weeks or months of recovery. As the complexity of the procedure increases, so do the chances for complications and failure.

People should check with their doctor to locate a surgeon experienced in performing specific procedures.

Two procedures—fulguration and resection of ulcers—can be done with instruments inserted through the urethra. Fulguration involves burning Hunner’s ulcers with electricity or a laser. When the area heals, the dead tissue and the ulcer fall off, leaving new, healthy tissue behind. Resection involves cutting around and removing the

*What I need to know about Bladder Control for Women* Insert B

### Your Daily Bladder Diary

This diary will help you and your health care team figure out the causes of your bladder control trouble. The “sample” line shows you how to use the diary.

Your name: \_\_\_\_\_

Date: \_\_\_\_\_

Time	Drinks		Trips to the Bathroom			Accidental Leaks			Did you feel a strong urge to go?	What were you doing at the time? <i>Sneezing, exercising, laughing, sex, lifting, etc.</i>
	<i>What kind?</i>	<i>How much?</i>	<i>How many times?</i>	<i>How much urine? (circle one)</i>	<i>How much? (circle one)</i>	<i>sm</i>	<i>med</i>	<i>lg</i>		
<b>Sample</b>	<b>Coffee</b>	<b>2 cups</b>	<input checked="" type="checkbox"/>	<input type="checkbox"/>	<input type="checkbox"/>	<input type="checkbox"/>	<input type="checkbox"/>	<input type="checkbox"/>	Yes <input checked="" type="checkbox"/> No <input type="checkbox"/>	<b>Running</b>
6–7 a.m.									Yes No	
7–8 a.m.									Yes No	
8–9 a.m.									Yes No	
9–10 a.m.									Yes No	
10–11 a.m.									Yes No	
11–12 noon									Yes No	
12–1 p.m.									Yes No	
1–2 p.m.									Yes No	
2–3 p.m.									Yes No	
3–4 p.m.									Yes No	
4–5 p.m.									Yes No	
5–6 p.m.									Yes No	
6–7 p.m.									Yes No	

Use this sheet as a master for making copies that you can use as a bladder diary for as many days as you need.

Bladder diary from *What I need to know about Bladder Control for Women* at [www.kidney.niddk.nih.gov](http://www.kidney.niddk.nih.gov)

ulcers. Both treatments are done under anesthesia and use special instruments inserted into the bladder through a cystoscope. Laser surgery in the urinary tract should be reserved for people with Hunner's ulcers and should be done only by doctors with the special training and expertise needed to perform the procedure.

Another surgical treatment is augmentation, which makes the bladder larger. In most of these procedures, scarred, ulcerated, and inflamed sections of the patient's bladder are removed, leaving only the base of the bladder and healthy tissue. A piece of the patient's colon—also called large intestine—is then removed, reshaped, and attached to what remains of the bladder. After the incisions heal, the patient may void less frequently. The effect on pain varies greatly; IC/PBS can sometimes recur on the segment of colon used to enlarge the bladder.

Even in carefully selected patients—those with small, contracted bladders—pain, frequency, and urgency may remain or return after surgery, and they may have additional problems with infections in the new bladder and difficulty absorbing nutrients from the shortened colon. Some patients become incontinent, while others cannot void at all and must insert a catheter into the urethra to empty the bladder.

Bladder removal, called a cystectomy, is another, infrequently used surgical option. Once the bladder has been removed, different methods can be used to reroute the urine. In most cases, ureters are attached to a piece of colon that opens onto the skin of the abdomen. This procedure is called a urostomy and the opening is called a stoma. Urine empties through the stoma into a bag outside the body. Some urologists are using

a second technique that also requires a stoma but allows urine to be stored in a pouch inside the abdomen. At intervals throughout the day, the patient puts a catheter into the stoma and empties the pouch. Patients with either type of urostomy must be very careful to keep the area in and around the stoma clean to prevent infection. Serious potential complications may include kidney infection and small bowel obstruction.

A third method to reroute urine involves making a new bladder from a piece of the patient's colon and attaching it to the urethra. After healing, the patient may be able to empty the newly formed bladder by voiding at scheduled times or by inserting a catheter into the urethra. Only a few surgeons have the special training and expertise needed to perform this procedure.

Even after total bladder removal, some patients still experience variable IC/PBS symptoms in the form of phantom pain. Therefore, the decision to undergo a cystectomy should be made only after testing all alternative methods and seriously considering the potential outcome.

Removing the bladder is not always done in patients with severe disease. Some urologists recommend rerouting urine to a piece of bowel connected to the abdominal wall. Urine is then collected in an external bag that is emptied periodically. While this procedure may or may not improve pelvic pain, it can decrease frequency and improve quality of life for patients who experience frequent urges to urinate.

## Are there any special concerns regarding IC/PBS?

### Cancer

No evidence exists that IC/PBS increases the risk of bladder cancer.

### Pregnancy

Researchers have little information about pregnancy and IC/PBS but believe that the disorder does not affect fertility or the health of the fetus. Some women find that their IC/PBS goes into remission during pregnancy, while others experience a worsening of their symptoms.

### Coping

The emotional support of family, friends, and other people with IC/PBS is very important in helping patients cope. Studies have found that people who learn about the disorder and become involved in their own care do better than people who do not. The Interstitial Cystitis Association maintains a list of support groups that can be viewed at [www.ichelp.org](http://www.ichelp.org).

## Hope through Research

Although answers may seem slow in coming, researchers are working to solve the painful riddle of IC/PBS. Some scientists receive funds from the Federal Government to help support their research, while others receive support from their employing institution, drug pharmaceutical or device companies, or patient support associations.

The NIDDK's investment in scientifically meritorious IC/PBS research across the United States has grown considerably since 1987. The Institute now supports research that looks at various aspects of IC/PBS, such as how the components of urine may injure the bladder and what role organisms identified by nonstandard methods may have

in causing IC/PBS. In addition to funding research, the NIDDK sponsors scientific workshops where investigators share the results of their studies and discuss future areas for investigation.

### Clinical Research Network

The Interstitial Cystitis Clinical Research Network (ICCRN) is a product of two NIDDK programs: the Interstitial Cystitis Database (ICDB) Study and the Interstitial Cystitis Clinical Trials Group (ICCTG). Established in 1991, the ICDB was a 5-year prospective cohort study of more than 600 men and women with symptoms of urinary urgency, frequency, and pelvic pain. The study described the longitudinal changes of urinary symptoms, the impact of IC on quality of life, treatment patterns, and the relationship between bladder biopsy findings and patient symptoms. The ICCTG was established in 1996 as a follow-up to the ICDB study. The clinical trials group developed two randomized, controlled clinical trials of promising therapies, one using oral therapies—pentosan polysulfate sodium (Elmiron) and hydroxyzine hydrochloride (Atarax)—and the other administering intravesical treatment using Bacillus Calmette-Guérin (BCG). BCG is a vaccine for tuberculosis that stimulates the immune system and may have an effect on the bladder. The ICCTG also developed and conducted ancillary studies of various biomarkers such as heparin-binding epidermal growth factor-like growth factor (HB-EGF) and anti-proliferative factor (APF).

In 2003, the ICCTG became the ICCRN, which has conducted additional clinical trials over a second 5-year period. One of these trials studied the effectiveness of amitriptyline in treating PBS, which includes IC. Amitriptyline has FDA approval for the treatment of depression, but researchers

believe the drug may work to block nerve signals that trigger pain in the bladder and may also decrease muscle spasms in the bladder, helping to cut both pain and frequent urination. The study could not prove that amitriptyline was effective in treating IC/PBS, although many patients seemed to benefit from a combination of amitriptyline and behavioral modification with stress reduction.

In 2008, the NIDDK launched the Multidisciplinary Approach to the Study of Chronic Pelvic Pain (MAPP) Research Network. The MAPP Research Network is designed to take a collaborative, whole-body approach to the study of IC/PBS and chronic prostatitis/chronic pelvic pain syndrome (CP/CPPS). This program brings together experts from nonurologic fields such as neurology and epidemiology as well as traditional urologic researchers to study IC/PBS and CP/CPPS in the context of other chronic pain syndromes such as fibromyalgia, chronic fatigue syndrome, and irritable bowel syndrome. While traditional research has focused on the bladder as the source of pain in IC/PBS and on the prostate as the source of pain in CP/CPPS, researchers now believe that an underlying cause common to all chronic pain syndromes may lie somewhere outside these specific organs. The MAPP Research Network includes six Discovery Sites that will conduct individual and collaborative trials and two Core Sites for data and tissue banking and analysis. The program is scheduled to be funded for 5 years.

Participants in clinical trials can play a more active role in their own health care, gain access to new research treatments before they are widely available, and help others by contributing to medical research. For information about current studies, visit [www.ClinicalTrials.gov](http://www.ClinicalTrials.gov).

## Suggested Reading

The materials listed below may be found in medical libraries, in many college and university libraries, through interlibrary loan in most public libraries, and at bookstores. Items are listed for information only; inclusion does not imply endorsement by the National Institutes of Health.

### Articles and Book Chapters

Keay SK, Warren JW. Is interstitial cystitis an infectious disease? *International Journal of Antimicrobial Agents*. 2002;19(6):480–483.

The Interstitial Cystitis Clinical Trials Group. A pilot clinical trial of oral pentosan polysulfate and oral hydroxyzine in patients with interstitial cystitis. *Journal of Urology*. 2003;170(3):810–815.

The Interstitial Cystitis Clinical Trials Group. A randomized controlled trial of intravesical Bacillus Calmette-Guérin for treatment of refractory interstitial cystitis. *Journal of Urology*. 2005;173(4):1186–1191.

Hanno P, Lin AT, Nordling J, Nyberg L, van Ophoven A, Ueda T. Bladder pain syndrome. In: Abrams P, Cardozo L, Khoury S, Wein A, eds. *Incontinence*. Paris: Health Publication Ltd.; 2009: 1459–1518.

### Books and Booklets

Moldwin RM. *The Interstitial Cystitis Survival Guide: Your Guide to the Latest Treatment Options and Coping Strategies*. Oakland, CA: New Harbinger Publications, Inc.; 2000. (Available by calling 1–800–HELP–ICA or 1–800–435–7422.)

Sandler GG, Sandler A. *Patient to Patient: Managing Interstitial Cystitis & Overlapping Conditions*. New Orleans, LA: Bon Ange LLC; 2000.

Sant G, ed. *Interstitial Cystitis*. Philadelphia: Lippincott-Raven; 1997.

## For More Information

### **American Urological Association Foundation**

1000 Corporate Boulevard  
Linthicum, MD 21090  
Phone: 1-866-RING-AUA (1-866-746-4282)  
or 410-689-3700  
Email: [patienteducation@auafoundation.org](mailto:patienteducation@auafoundation.org)  
Internet: [www.auafoundation.org](http://www.auafoundation.org)  
[www.UrologyHealth.org](http://www.UrologyHealth.org)

### **American Chronic Pain Association**

P.O. Box 850  
Rocklin, CA 95677  
Phone: 1-800-533-3231  
Email: [ACPA@pacbell.net](mailto:ACPA@pacbell.net)  
Internet: [www.theacpa.org](http://www.theacpa.org)

### **American Pain Society**

4700 West Lake Avenue  
Glenview, IL 60025  
Phone: 847-375-4715  
Email: [info@ampainsoc.org](mailto:info@ampainsoc.org)  
Internet: [www.ampainsoc.org](http://www.ampainsoc.org)

### **American Urogynecologic Society**

2025 M Street NW, Suite 800  
Washington, D.C. 20036  
Phone: 202-367-1167  
Fax: 202-367-2167  
Email: [info@aug.org](mailto:info@aug.org)  
Internet: [www.aug.org](http://www.aug.org)

### **International Association for the Study of Pain**

111 Queen Anne Avenue North, Suite 501  
Seattle, WA 98109-4955  
Phone: 206-283-0311  
Email: [IASPdesk@iasp-pain.org](mailto:IASPdesk@iasp-pain.org)  
Internet: [www.iasp-pain.org](http://www.iasp-pain.org)

### **Interstitial Cystitis Association**

100 Park Avenue, Suite 108A  
Rockville, MD 20850  
Phone: 1-800-HELP-ICA (1-800-435-7422)  
or 301-610-5300  
Fax: 301-610-5308  
Email: [ICAmail@ichelp.org](mailto:ICAmail@ichelp.org)  
Internet: [www.ichelp.org](http://www.ichelp.org)

### **National Kidney Foundation**

30 East 33rd Street  
New York, NY 10016  
Phone: 1-800-622-9010 or 212-889-2210  
Internet: [www.kidney.org](http://www.kidney.org)

### **National Organization of Social Security Claimants' Representatives**

560 Sylvan Avenue  
Englewood Cliffs, NJ 07632  
Phone: 1-800-431-2804  
Email: [nosscr@att.net](mailto:nosscr@att.net)  
Internet: [www.nosscr.org](http://www.nosscr.org)

### **Social Security Administration**

Office of Public Inquiries  
Windsor Park Building  
6401 Security Boulevard  
Baltimore, MD 21235  
Phone: 1-800-772-1213  
Internet: [www.ssa.gov](http://www.ssa.gov)

Local offices can be found in the telephone book under U.S. Government, Department of Health and Human Services.

### **United Ostomy Associations of America**

P.O. Box 66  
Fairview, TN 37062-0066  
Phone: 1-800-826-0826  
Email: [info@uoaa.org](mailto:info@uoaa.org)  
Internet: [www.uoaa.org](http://www.uoaa.org)

## Acknowledgments

Publications produced by the Clearinghouse are carefully reviewed by both NIDDK scientists and outside experts. This publication was reviewed by Philip Hanno, M.D., University of Pennsylvania.

You may also find additional information about this topic by visiting MedlinePlus at [www.medlineplus.gov](http://www.medlineplus.gov).

This publication may contain information about medications. When prepared, this publication included the most current information available. For updates or for questions about any medications, contact the U.S. Food and Drug Administration toll-free at 1-888-INFO-FDA (1-888-463-6332) or visit [www.fda.gov](http://www.fda.gov). Consult your doctor for more information.

The U.S. Government does not endorse or favor any specific commercial product or company. Trade, proprietary, or company names appearing in this document are used only because they are considered necessary in the context of the information provided. If a product is not mentioned, the omission does not mean or imply that the product is unsatisfactory.

## National Kidney and Urologic Diseases Information Clearinghouse

3 Information Way  
Bethesda, MD 20892-3580  
Phone: 1-800-891-5390  
TTY: 1-866-569-1162  
Fax: 703-738-4929  
Email: [nkudic@info.niddk.nih.gov](mailto:nkudic@info.niddk.nih.gov)  
Internet: [www.urologic.niddk.nih.gov](http://www.urologic.niddk.nih.gov)

The National Kidney and Urologic Diseases Information Clearinghouse (NKUDIC) is a service of the National Institute of Diabetes and Digestive and Kidney Diseases (NIDDK). The NIDDK is part of the National Institutes of Health of the U.S. Department of Health and Human Services. Established in 1987, the Clearinghouse provides information about diseases of the kidneys and urologic system to people with kidney and urologic disorders and to their families, health care professionals, and the public. The NKUDIC answers inquiries, develops and distributes publications, and works closely with professional and patient organizations and Government agencies to coordinate resources about kidney and urologic diseases.

This publication is not copyrighted. The Clearinghouse encourages users of this publication to duplicate and distribute as many copies as desired.

This publication is available at [www.urologic.niddk.nih.gov](http://www.urologic.niddk.nih.gov).



U.S. DEPARTMENT OF HEALTH  
AND HUMAN SERVICES  
National Institutes of Health

NIH Publication No. 10-3220  
December 2009